

Journal of Mathematics and Music
Vol. 00, No. 00, January 2008, 1–15

Research Article

Structural Properties of Euclidean Rhythms

Francisco Gómez-Martín^a, Perouz Taslakian^{b*}, and Godfried Toussaint^b

^a*Departamento de Matemática Aplicada, Escuela Universitaria de Informática
Ctra. de Valencia, Universidad Politécnica de Madrid, Km. 7, 28031, Madrid,
Spain. Email: fmartin@eui.upm.es*

^b*School of Computer Science, CIRMMT, McGill University, 3480 University
Street Room 318, Montréal, QC, Canada, H3A 2A7. Email:
{perouz,godfried}@cs.mcgill.ca*

(Received 00 Month 200x; final version received 00 Month 200x)

In this paper we investigate the structure of Euclidean rhythms and show that a Euclidean rhythm is formed of a pattern, called the *main pattern*, repeated a certain number of times, followed possibly by one extra pattern, the *tail pattern*. We thoroughly study the recursive nature of Euclidean rhythms when generated by Bjorklund's algorithm, one of the many algorithms that generate Euclidean rhythms. We make connections between Euclidean rhythms and Bezout's theorem. We also prove that the decomposition obtained is minimal.

Keywords: Euclidean rhythms; maximally even.

MCS/CCS/AMS Classification/CR Category numbers: 11A05; 52C99; 51K99;

1. Introduction

Euclidean rhythms are a class of musical rhythms where the onsets are spread out among the pulses *as evenly as possible*. They are a subclass of the family of *maximally even sets* introduced by Clough and Myerson [6], and later expanded by Clough and Douthett [5]. This property of objects being spread out evenly has been rediscovered independently in

*Corresponding author. Email: perouz@cs.mcgill.ca

disparate disciplines such as music, nuclear physics, computer graphics, calendar design, and combinatorics of words, to name a few. In music theory several authors have explored the idea of evenness in the pitch domain from several standpoints. Carey and Clampit [4] gave a definition of self-similarity and proved that this property identifies a group of scales having common features with the diatonic. Their definition, which is related to the Euclidean rhythms to be studied here, could also be transferred to the rhythmic domain. Lewin [15] generalized Cohn sets to Cohn functions for pitch classes, and suggested several methods for realizing them on the rhythmic domain. In fact, Lewin anticipated the study of Euclidean strings before the paper by Ellis [11]. Demaine et al. [10] have conducted a thorough study of Euclidean rhythms, their mathematical properties, and their connections with other fields, music in particular; for example, they provide a list of more than forty Euclidean rhythms of n pulses and k onsets (for several values of n and k) that are found in a broad range of world music. Euclidean rhythms can be generated by an algorithm described by Bjorklund [1], which closely resembles Euclid's algorithm for finding the greatest common divisor of two integers.

Euclidean rhythms appear in computer graphics literature, in topics related to drawing digital straight lines [14]. The problem here is to efficiently convert a mathematical straight line segment defined by the (x, y) integer coordinates of its endpoints to an ordered sequence of pixels that faithfully represents the straight line segment. Indeed, Harris and Reingold [13] show that the well-known Bresenham algorithm [2] for drawing digital straight lines on a computer screen is implemented by the Euclidean algorithm. Bruckstein [3] presents several self-similarity properties of digital straight lines (Euclidean rhythms), and independently shows that the complement of a Euclidean rhythm is also Euclidean. Since a digital straight line yields a sequence that is a Euclidean rhythm, we might naturally pose the converse question [12]: when can a string of integers h_i (for $i = 1, 2, \dots, n$) be represented as $h_i = \lfloor ri + s \rfloor$, for fixed real numbers r and s , Reinhard Klette and Azriel Rosenfeld have written an excellent survey of the properties of digital straight lines and their many connections to geometry and number theory [14].

The Euclidean rhythms considered here are known by different names in several areas of mathematics. In the algebraic combinatorics of words they are called *Sturmian* words [16]. Lunnon and Pleasants call them *two-distance* sequences [17], and de Bruijn calls them *Beatty* sequences [8, 9]. See also the geometry of Markoff numbers [18]. In the study of the combinatorics of words and sequences, there is a family of strings called *Euclidean strings* [11]. Ellis et al. [11] define a string $\Pi = (\pi_0, \pi_1, \dots, \pi_{n-1})$ as a *Euclidean string* if increasing π_0 by one and decreasing π_{n-1} by one yields a new string, denoted by $\tau(\Pi)$, that is a rotation of Π .

In this paper, we continue the work of Demaine et al. [10] and further investigate properties of Euclidean rhythms. We focus on the internal structure of this class of rhythms and show that a Euclidean rhythm can be decomposed into a repeating rhythmic pattern that is itself Euclidean. We also prove that such a decomposition is minimal (to be defined later). Furthermore, we present a clear connection between Euclidean rhythms and each of Euclid's algorithm and Bezout's theorem.

2. Notation and Basic Definitions

In this paper we will use three main representations of rhythms. The first representation is the binary string representation where the 1-bits are the onsets of the rhythm and the 0-bits are the rests. The second is the *subset* notation, where the onsets are written as a subset of the n pulses numbered from 0 to $n - 1$. The third representation we use is the *clockwise distance sequence*, where the clockwise distance between a pair of consecutive onsets around the circular lattice is represented by an integer; these integers together sum to the total number of pulses.

As an example, consider the Cuban clave *son* rhythm. Its three representations are 1001001000101000 in the binary string notation, $\{0, 3, 6, 10, 12\}$ in subset notation, and $(3, 3, 4, 2, 4)$ in clockwise distance sequence notation.

Let $E(k, n)$ denote the Euclidean rhythm with k onsets and n pulses generated by Bjorklund's algorithm [1] (to be described later), and let $E_{CD}(k, n)$ denote the Euclidean rhythm with k onsets and n pulses generated by the *Clough-Douthett* algorithm described in [10]. The onsets of $E_{CD}(k, n)$ are given by the sequence:

$$E_{CD}(k, n) = \left\{ \left\lfloor \frac{in}{k} \right\rfloor : i = 0, 1, \dots, k - 1 \right\}. \quad (1)$$

For any two rhythms R_1 and R_2 we let $R_1 \oplus R_2$ denote the rhythm composed of the pulses of R_1 followed by the pulses R_2 ; this is known as the *concatenation* of R_1 and R_2 . Finally, we denote the greatest common divisor of two integers k and n by $\gcd(k, n)$.

3. Structure of Euclidean Rhythms

Demaine et al. [10] present four algorithms that generate Euclidean rhythms. In this paper we will refer to two of these algorithms: Bjorklund's algorithm and Clough and Douthett's algorithm. Both algorithms produce the same Euclidean rhythms up to a rotation [10]. Bjorklund's algorithm [1] is inspired by Euclid's algorithm for finding the greatest common divisor of two integers. For completeness, we describe both Euclid's and Bjorklund's algorithms below.

Euclid's algorithm. This algorithm is based on the property that the greatest common divisor of two integers a and b , where $a > b$, is the same as the greatest common divisor of b and $a \bmod b$. As an example, let us compute $\gcd(17, 7)$. Since $17 = \underline{7} \times 2 + \underline{3}$, then the equality $\gcd(17, 7) = \gcd(7, 3)$ holds. Again, since $7 = \underline{3} \times 2 + \underline{1}$, then $\gcd(17, 7) = \gcd(3, 1)$, and therefore $\gcd(17, 7) = 1$. Underlined numbers indicate the pairs obtained through successive divisions. In general, Euclid's algorithm stops when the remainder is equal to 1 or 0. If the remainder is 1, then the original two numbers are relatively prime; otherwise, the greatest common divisor is greater than 1 and is equal to the divisor of the last division performed.

Bjorklund's algorithm. Bjorklund's algorithm consists of two steps: an initialization

step, performed once at the beginning; and, a subtraction step, performed repeatedly until the stopping condition is satisfied. At all times Bjorklund’s algorithm maintains two lists A and B of strings of bits, with a and b representing the number of strings in each list, respectively.

- (1) **Initialization step.** In this step the algorithm builds the string $\{1, \dots, k, \dots, 1, 0, \dots, n-k, 0\}$, and sets A as the first $a = \min\{k, n - k\}$ bits of that string, and B as the remaining $b = \max\{k, n - k\}$ bits. Next the algorithm removes $\lfloor b/a \rfloor$ strings of a consecutive bits from B , starting with the rightmost bit, and places them under the a -bit strings in A one below the other (see Figure 1, steps (1) and (2)). Lists A and B are then redefined: A is now composed of a strings (the a columns in A), each having $\lfloor b/a \rfloor + 1$ bits, and B is composed of $b \bmod a$ strings of 0-bits. Finally, the algorithm sets $b = b \bmod a$.
- (2) **Subtraction step.** At a subtraction step, the algorithm removes $\lfloor a/b \rfloor$ strings of b consecutive bits (or columns) from B and A , starting with the rightmost bit of B and continuing with the rightmost bit of A , and places them at the bottom-left of the strings in A one below the other. Lists A and B are then redefined as follows: A is composed of the first b strings (starting with the leftmost bit), while B is composed of the remaining $a \bmod b$ strings. Finally, the algorithm sets $b = a \bmod b$ and $a = b$ (before b was redefined). See Figure 1, step (3).

The algorithm stops when, after the end of a subtraction step list B is empty or consists of one string. The output then is produced by concatenating the strings of A from left to right and the strings of B , if not empty; see Figure 1, step (4).

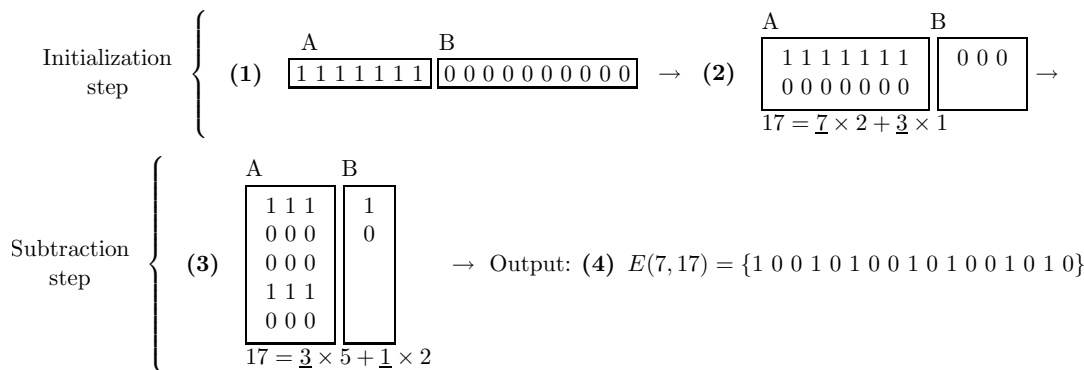

Figure 1. Bjorklund’s algorithm for generating the Euclidean rhythm $E(7, 17)$. In the initialization step, a is set to 7, and b is set to 10. In Step (2), the algorithm removes $\lfloor 10/7 \rfloor = 1$ string of 7 bits from B and places it under the string in A . List A is now composed of seven 2-bit strings [10], while list B is composed of three 1-bit strings [0] (think of each string as one column in box A or B). The new values of a and b are 7 and 3 respectively (the underlined digits in Step (2)). In the subtraction step (Step (3)), the algorithm takes $\lfloor 7/3 \rfloor = 2$ strings of 3 bits (columns) each from B and A (starting with the rightmost column in B) and places them at the bottom-left of A , one below the other. The algorithm now stops because B is formed of the single string [10].

If all the divisions of Euclid’s algorithm are performed one inside the other, and the

terms rearranged appropriately as shown in the example below, an expression that keeps track of the dimensions of lists A and B in Bjorklund's algorithm is found. For the example in Figure 1 we have:

$$\begin{aligned} 17 &= \underline{7} \times 1 + \underline{10} \times 1 = \underline{7} \times 1 + (\underline{7} \times 1 + \underline{3} \times 1) \times 1 = \underline{7} \times 2 + \underline{3} \times 1 \\ &= (\underline{3} \times 2 + \underline{1} \times 1) \times 2 + \underline{3} \times 1 = \underline{3} \times 5 + \underline{1} \times 2 \end{aligned}$$

Let us establish now the relationship between Euclid's and Bjorklund's algorithms. Both perform the same operations, the former on numbers, while the latter on strings of bits. At some subtraction step, Bjorklund's algorithm first performs the division $\lfloor a/b \rfloor$ by moving bits from B to A , after which it sets b as the number of strings in A and $a \bmod b$ as the number of strings in B . This is exactly what Euclid's algorithm does at a subtraction step: it sets $b, a \bmod b$ as the new pair (for $a > b$). When $k \leq n - k$, the initialization step of Bjorklund's algorithm also produces the same numbers as the first execution of Euclid's algorithm. However, if $k > n - k$, this is no longer true. In this case the initialization step sets $a = n - k$ and $b = k$; after moving the bits needed to build lists A and B , the number of strings turns out to be $n - k$ and $k \bmod (n - k)$. These numbers coincide with the numbers obtained after executing two steps of Euclid's algorithm: $(k, n - k)$ for the first step and $(n - k, k \bmod (n - k))$ for the second.

For example, consider computing $\gcd(27, 10)$ using Euclid's algorithm. The sequence generated during its execution is $\{\gcd(10, 7), \gcd(7, 3), \gcd(3, 1)\}$. When applying Bjorklund's algorithm the sequence formed by the number of strings at each step is also $\{\gcd(10, 7), \gcd(7, 3), \gcd(3, 1)\}$. On the other hand, if we compute $\gcd(27, 17)$, the sequence associated with Euclid's algorithm is $\{\gcd(17, 10), \gcd(10, 7), \gcd(7, 3), \gcd(3, 1)\}$, whereas the sequence associated with Bjorklund's algorithm is $\{\gcd(10, 7), \gcd(7, 3), \gcd(3, 1)\}$. This example also illustrates the fact that the sequence provided by Bjorklund's algorithm is the same for both $E(k, n)$ and $E(n - k, n)$.

Once Bjorklund's algorithm is completed, we obtain two lists A and B that form the Euclidean rhythm $E(k, n)$. It follows that $E(k, n)$ is composed of the concatenation of a pattern P given by the strings of A , and (possibly) the concatenation of a single pattern T given by the only string in list B . We call P the *main pattern* of $E(k, n)$ and T the *tail pattern*.

Let us introduce at this point some notation to be used throughout the rest of this paper. The length of the main pattern P will be denoted by ℓ_p , the length of the tail pattern T by ℓ_t , and the number of times P is repeated in $E(k, n)$ by p . For any k and n , the following equality holds:

$$n = \ell_p \times p + \ell_t \tag{2}$$

Analogously, let us call k_p the number of onsets of the main pattern P and k_t the number of onsets of the tail pattern T . When $\gcd(k, n) = 1$, k can be written as:

$$k = k_p \times p + k_t \tag{3}$$

Additionally, if $\gcd(k, n) = d > 1$, it follows that $p = d$ and $\ell_t = 0$. Hence, $n = \ell_p \times d$, and $k = k_p \times p$.

$$\begin{aligned}
 & \underbrace{1111111111111111}_{k} \underbrace{0000}_{n-k} \implies \text{(Initialization step)} \\
 & \left\lfloor \frac{n}{n-k} \right\rfloor \left\{ \begin{array}{l} 1 \ 1 \ 1 \ 1 \ 1 \ 1 \ 1 \\ 0 \ 0 \ 0 \ 0 \\ 1 \ 1 \ 1 \ 1 \\ 1 \ 1 \ 1 \ 1 \end{array} \right. \implies \text{(Replacement: } \begin{pmatrix} 1 \\ 0 \\ 1 \\ 1 \end{pmatrix} \rightarrow \Theta) \\
 & \qquad \qquad \qquad \underbrace{\hspace{10em}}_{n-k} \underbrace{\hspace{10em}}_r \\
 & \Theta \Theta \Theta \Theta 1111 \implies \underbrace{\begin{array}{l} \Theta \ \Theta \ \Theta \ \Theta \\ 1 \ 1 \ 1 \end{array}}_{E^*(n-k, n-k+r)} \implies \text{(Replacement: } \Theta \rightarrow \begin{pmatrix} 1 \\ 0 \\ 1 \\ 1 \end{pmatrix}) \\
 & \begin{array}{l} 1 \ 1 \ 1 \ 1 \\ 0 \ 0 \ 0 \ 0 \\ 1 \ 1 \ 1 \ 1 \\ 1 \ 1 \ 1 \ 1 \\ 1 \ 1 \ 1 \end{array} = E(k, n)
 \end{aligned}$$

Figure 2. Proof of Lemma 3.1, case $k > n - k$.

One natural question to ask is whether patterns P and T are themselves Euclidean. We will show below that this indeed is the case. We will first prove two technical lemmas.

LEMMA 3.1 *Let $E(k, n)$ be a Euclidean rhythm where $1 \leq k < n$ and let $d = \text{gcd}(k, n)$. The following equalities hold:*

- (a) *If $d > 1$, then $nk_p - k\ell_p = 0$.*
- (b) *If $d = 1$, then $nk_p - k\ell_p = \pm 1$ and $\ell_t k_p - k_t \ell_p = \pm 1$.*

Proof: If $d > 1$, then $n = d\ell_p$ and $k = dk_p$, and a simple computation proves this case: $d = \frac{n}{\ell_p} = \frac{k}{k_p}$, and therefore $nk_p - k\ell_p = 0$.

For the case $d = 1$, we will prove the result by induction on k . If $k = 1$, then $E(1, n)$ is the rhythm $\{10 \ . \ . \ . \ . \ 0\}$ with $P = \{10 \ . \ . \ . \ . \ 0\}$ and $T = \{0\}$. For this rhythm $\ell_p = n - 1, k_p = 1$ and the required equality holds since $n \cdot 1 - 1 \cdot (n - 1) = 1$.

For the inductive step, assume the statement is true for all values less than k . Consider first the case $n - k < k$. When the initialization step of Bjorklund’s algorithm is executed, it produces a list A of $n - k$ strings of $\left\lfloor \frac{n}{n-k} \right\rfloor$ bits each, and a list B of $r = n \bmod (n - k)$ strings of one bit. In other words, it performs the division:

$$n = (n - k) \left\lfloor \frac{n}{n - k} \right\rfloor + r \tag{4}$$

At this point we replace each string in list A by the symbol Θ . This replacement transforms lists A and B into the string $\{\Theta \ . \ . \ . \ . \ \Theta 1 \ . \ . \ . \ 1\}$. If we apply Bjorklund’s algorithm to this string, we will obtain a Euclidean rhythm $E^*(n - k, n - k + r)$ (here symbols Θ play the role of onsets and the 1’s those of rests). When the inverse replacement is performed on $E^*(n - k, n - k + r)$, that is, when Θ is replaced by the original string in A , the Euclidean rhythm $E(k, n)$ is recovered. Figure 2 shows the entire process.

By equation 4, it follows that $r < n - k$; this implies that $n - k + r - (n - k) < n - k$. Therefore, we can apply the induction hypothesis to $E^*(n - k, n - k + r)$. Thus, we have $(n - k + r)k'_p - (n - k)l'_p = \pm 1$, where k'_p is the number of onsets (that is, Θ 's) in the main pattern of $E^*(n - k, n - k + r)$, and l'_p is the number of pulses. The following equations show the relationship between k'_p, l'_p and k_p, l_p .

- $k'_p = l_p - k_p$, since the number of Θ 's in the main pattern of $E^*(n - k, n - k + r)$ is equal to the number of zeroes in $E(k, n)$.
- $l_p = k'_p \left\lfloor \frac{n}{n-k} \right\rfloor + l'_p - k'_p$, where the first term of the right-hand side accounts for the expansion of Θ , while the last two terms account for the number of ones in $E^*(n - k, n - k + r)$.

Applying the induction hypothesis to $E^*(n - k, n - k + r)$, together with equation (4) we obtain:

$$\begin{aligned} \pm 1 &= (n - k + r)k'_p - (n - k)l'_p = rk'_p - (n - k)(l'_p - k'_p) \\ &= rk'_p - (n - k) \left(l_p - k'_p \left\lfloor \frac{n}{n-k} \right\rfloor \right) = rk'_p - (n - k)l_p + k'_p(n - r) = nk'_p - (n - k)l_p \\ &= kl_p - n(l_p - k'_p) = kl_p - nk_p. \end{aligned}$$

We now turn to the case when $n - k > k$. The proof is similar to the previous case. As above, the initialization step of Bjorklund's algorithm is first applied to the input string $\{1 \cdot^k \cdot 10 \cdot^{n-k} \cdot 0\}$. Each string in list A is now replaced by the symbol \mathcal{I} . This yields the string $\{\mathcal{I} \cdot^k \cdot \mathcal{I}0 \cdot^r \cdot 0\}$, where $r = n \bmod k$. Next we execute Bjorklund's algorithm on string $\{\mathcal{I} \cdot^k \cdot \mathcal{I}0 \cdot^r \cdot 0\}$, which produces a Euclidean rhythm $E^*(k, k + r)$ composed of \mathcal{I} 's and 0's. Figure 3 illustrates these transformations. Note that we cannot apply induction here as the number of onsets in $E^*(k, k + r)$ is not less than k . However, since $k + r - k = r < k$ we can apply the result of the first case to $E^*(k, k + r)$ and write $t(k + r)k'_p - kl'_p = \pm 1$, where k'_p is the number of onsets in the main pattern of $E^*(k, k + r)$, and l'_p the number of pulses.

Again, we need to relate the main patterns of $E^*(k, k + r)$ and $E(k, n)$ in order to derive the final formula.

- $k'_p = k_p$, since the number of \mathcal{I} 's in $E^*(k, k + r)$ is equal to the number of ones in $E(k, n)$.
- $l_p = k'_p \left\lfloor \frac{n}{k} \right\rfloor + l'_p - k'_p$, where the first term on the right-hand side accounts for the expansion of \mathcal{I} , while the last two terms account for the number of zeroes in $E^*(k, k + r)$.

We can now carry out a similar manipulation as above to prove the result:

$$\begin{aligned} \pm 1 &= (k + r)k'_p - kl'_p = rk'_p - k(l'_p - k'_p) = rk'_p - k \left(l_p - k'_p \left\lfloor \frac{n}{k} \right\rfloor \right) \\ &= rk'_p - kl_p + k'_p(n - r) = nk'_p - kl_p = nk_p - kl_p. \end{aligned}$$

$$\begin{array}{l}
 \underbrace{1111}_{k} \underbrace{0000000000000000}_{n-k} \implies \text{(Initialization step)} \\
 \lfloor \frac{n}{k} \rfloor \left\{ \begin{array}{l} 1 \ 1 \ 1 \ 1 \ 0 \ 0 \ 0 \\ 0 \ 0 \ 0 \ 0 \\ 0 \ 0 \ 0 \ 0 \\ 0 \ 0 \ 0 \ 0 \end{array} \right. \implies \text{(Replacement: } \begin{pmatrix} 1 \\ 0 \\ 0 \\ 0 \end{pmatrix} \rightarrow \mathcal{I}) \\
 \underbrace{\hspace{10em}}_k \underbrace{\hspace{10em}}_r \\
 \mathcal{I} \mathcal{I} \mathcal{I} \mathcal{I} 000 \implies \underbrace{\begin{array}{l} \mathcal{I} \ \mathcal{I} \ \mathcal{I} \ \mathcal{I} \\ 0 \ 0 \ 0 \end{array}}_{E^*(k, k+r)} \implies \text{(Replacement: } \mathcal{I} \rightarrow \begin{pmatrix} 1 \\ 0 \\ 0 \\ 0 \end{pmatrix}) \\
 \begin{array}{l} 1 \ 1 \ 1 \ 1 \\ 0 \ 0 \ 0 \ 0 \\ 0 \ 0 \ 0 \ 0 \\ 0 \ 0 \ 0 \ 0 \\ 0 \ 0 \ 0 \end{array} = E(k, n)
 \end{array}$$

Figure 3. Proof of Lemma 3.1, case $k < n - k$.

Finally, we prove that the equality $\ell_t k_p - k_t \ell_p = \pm 1$ holds. Using equations (2) and (3) together with the above result we obtain:

$$\begin{aligned}
 \pm 1 &= nk_p - k\ell_p = (p\ell_p + \ell_t)k_p - (pk_p + k_t)\ell_p \\
 &= p\ell_p k_p + \ell_t k_p - pk_p \ell_p - k_t \ell_p = \ell_t k_p - k_t \ell_p
 \end{aligned}$$

This completes the proof of the lemma. ■

The reader may have noticed a connection between Lemma 3.1 and Bezout’s theorem [7]. Given two integers a and b , Bezout’s theorem states that there exist two integers x and y such that $ax + by = \text{gcd}(a, b)$. When k and n are relatively prime, Lemma 3.1 states that k_p and ℓ_p are the absolute value of their Bezout coefficients. It also states that the absolute value of the Bezout coefficients of k_p and ℓ_p are ℓ_t and k_t , respectively.

Note that when n is a number such that $n = 1 \pmod k$, the tail pattern of $E(k, n)$ is just $\{0\}$. By convention, we will consider that $\{0\}$ is the Euclidean rhythm $E(0, 1)$. This is due to the fact that in this particular case Bjorklund’s algorithm performs only the initialization step. Otherwise, it follows from the description of Bjorklund’s algorithm that the tail pattern consists of the first ℓ_t pulses of P .

OBSERVATION 3.2 *Given a fixed integer $j \geq 0$, the rhythm $\left\{ \left\lfloor \frac{(i+j)n}{k} \right\rfloor \pmod n, i = 0, \dots, k-1 \right\}$ is $E_{CD}(k, n)$ starting from the onset at position j . The rhythm $\left\{ j + \left\lfloor \frac{in}{k} \right\rfloor \pmod n, i = 0, \dots, k-1 \right\}$ is a rotation of $E_{CD}(k, n)$ to the right by j positions.*

For example, let us take rhythm $E_{CD}(7, 24) = \left\{ \left\lfloor \frac{24i}{7} \right\rfloor \pmod{24}, i = 0, \dots, 6 \right\} =$

$\{0, 3, 6, 10, 13, 17, 20\}$. The rhythm $\left\{ \left\lfloor \frac{(i+3)24}{7} \right\rfloor \bmod 24, i = 0, \dots, 6 \right\}$ is $\{10, 13, 17, 20, 0, 3, 6\}$, which is just a reordering of $E_{CD}(7, 24)$ with exactly the same onsets. On the other hand, the formula $\left\{ 3 + \left\lfloor \frac{24i}{7} \right\rfloor \bmod 24, i = 0, \dots, 6 \right\} = \{3, 6, 9, 13, 16, 20, 23\}$ produces a rhythm with onsets at different positions from those of $E_{CD}(7, 24)$. This rhythm is a rotation of $E_{CD}(7, 24)$ by 3 positions to the right.

A rhythm of the form $\left\{ -\left\lfloor \frac{jn}{k} \right\rfloor + \left\lfloor \frac{(i+j)n}{k} \right\rfloor \bmod n, i = 0, \dots, k-1 \right\}$ is a rotation of $E_{CD}(k, n)$ generated by listing $E_{CD}(k, n)$ from the onset at position j . For example, the rhythm

$R = \left\{ -\left\lfloor \frac{3 \cdot 24}{7} \right\rfloor + \left\lfloor \frac{(i+3)24}{7} \right\rfloor \bmod 24, i = 0, \dots, 6 \right\}$ is $\{0, 3, 7, 10, 14, 17, 20\}$. By comparing the clockwise distance sequences of $E_{CD}(7, 24) = (3\ 3\ 4\ 3\ 4\ 3\ 4)$ and $R = (3\ 4\ 3\ 4\ 3\ 3\ 4)$, it is proven that R is $E_{CD}(7, 24)$ when listed from the onset at position 3.

Lastly, consider the clockwise distance sequence of $E_{CD}(k, n)$, say, $\{d_0, d_1, \dots, d_{k-1}\}$. Distances d_i are equal to $\left\lfloor \frac{n(i+1)}{k} \right\rfloor - \left\lfloor \frac{ni}{k} \right\rfloor$ and this expression can only take values of $\left\lfloor \frac{n}{k} \right\rfloor$ or $\left\lceil \frac{n}{k} \right\rceil$. As shown in [10], $E(k, n)$ and $E_{CD}(k, n)$ are the same rhythm up to a rotation. Therefore, there exists an index s such that $\{d_s, d_{s+1}, \dots, d_{k-1}, d_0, d_1, \dots, d_{s-1}\}$ is the clockwise distance sequence of $E(k, n)$. Set $m = \sum_{i=0}^s d_i$. Thus, the position of the i -th onset of $E(k, n)$ is given by the following formula:

$$-m + \left\lfloor \frac{n \cdot (i + s)}{k} \right\rfloor. \tag{5}$$

For example, the clockwise distance sequence of $E(7, 17)$ is $C_1 = (3, 2, 3, 2, 3, 2, 2)$, while the clockwise distance sequence of $E_{CD}(7, 17)$ is $C_2 = (2, 2, 3, 2, 3, 2, 3)$. A rotation of C_2 to the left by 4 transforms C_2 into C_1 . Then, $s = 1$ and $m = 2 + 2$. Therefore, the formula $-4 + \left\lfloor \frac{17 \cdot (i+2)}{7} \right\rfloor$, for $i = 0, \dots, 6$ generates the onsets of $E(7, 17) = \{0, 3, 5, 8, 10, 13, 15\}$.

We now proceed to prove the second technical lemma.

LEMMA 3.3 *Let $E(k, n) = P \oplus .^p. \oplus P \oplus T$ be a Euclidean rhythm. Let $E^*(k, n)$ be a rotation of $E(k, n)$ such that $E^*(k, n) = P' \oplus .^p. \oplus P' \oplus T'$, where $|P'| = \ell_p$ and $|T'| = \ell_t$. Then, P is a rotation of P' .*

Proof: If there is no P' that is a subrhythm of $P \oplus P$, then P' must be a subrhythm of $P \oplus T$. In this case the number of subrhythms P in $E(k, n)$ is at most two. If $E(k, n)$ has only one pattern P , then $n \equiv 1 \pmod k$. In this case $T = \{0\}$ and P is the rhythm $\{1\ 0 \dots \lfloor n/k \rfloor \dots 0\}$. For P' to have ℓ_p pulses when P' is not the same as P , P' must start on the second pulse of P . This forces P to be equal to an only-rest rhythm, which leads to a contradiction since $E^*(k, n)$ would also come to an only-rest rhythm. If $E(k, n)$ has two patterns P , then at least one such P' has its first j pulses in P and its last $n - j$ pulses in T . From Bjorklund's algorithm we know that when there is more than one pattern P , the tail T of $E(k, n)$ is composed of the first ℓ_t pulses of P (when $n \not\equiv 1 \pmod k$). In this case, it turns out that P' consists of the last $\ell_p - j$ pulses of P , for some j with $j \leq \ell_t$, followed by the first j pulses of P . Again by Observation 3.2, P' is a rotation of P . ■

THEOREM 3.4 *The main pattern of rhythm $E(k, n)$ is Euclidean up to a rotation.*

Proof: Consider first the case $\gcd(k, n) > 1$. By applying Clough and Douthett's formula (1) and expressions (2) and (3) we can write $E(k, n)$ as follows.

$$\begin{aligned}
 E_{CD}(k, n) &= \left\{ 0, \left\lfloor \frac{n}{k} \right\rfloor, \dots, \left\lfloor \frac{(k-1)n}{k} \right\rfloor \right\} = \left\{ 0, \left\lfloor \frac{\ell_p}{k_p} \right\rfloor, \dots, \left\lfloor \frac{(k-1)\ell_p}{k_p} \right\rfloor \right\} \\
 &= \left\{ 0, \left\lfloor \frac{\ell_p}{k_p} \right\rfloor, \dots, \left\lfloor \frac{(k_p-1)\ell_p}{k_p} \right\rfloor, \left\lfloor \frac{\ell_p k_p}{k_p} \right\rfloor, \left\lfloor \frac{\ell_p(k_p+1)}{k_p} \right\rfloor, \dots, \left\lfloor \frac{\ell_p k_p + \ell_p(k_p-1)}{k_p} \right\rfloor, \right. \\
 &\quad \left. \dots, \dots, \left\lfloor \frac{\ell_p k_p(p-1)}{k_p} \right\rfloor, \left\lfloor \frac{\ell_p(k_p(p-1)+1)}{k_p} \right\rfloor, \dots, \left\lfloor \frac{\ell_p k_p(p-1) + \ell_p(k_p-1)}{k_p} \right\rfloor \right\} \\
 &= \left\{ 0, \left\lfloor \frac{\ell_p}{k_p} \right\rfloor, \dots, \left\lfloor \frac{(k_p-1)\ell_p}{k_p} \right\rfloor, \ell_p, \ell_p + \left\lfloor \frac{\ell_p}{k_p} \right\rfloor, \dots, \ell_p + \left\lfloor \frac{\ell_p(k_p-1)}{k_p} \right\rfloor, \right. \\
 &\quad \left. \dots, \dots, \ell_p(p-1), \dots, \ell_p(p-1) + \left\lfloor \frac{\ell_p(k_p-1)}{k_p} \right\rfloor \right\} \\
 &= E_{CD}(k_p, \ell_p) \oplus E_{CD}(k_p, \ell_p) \oplus \dots \oplus E_{CD}(k_p, \ell_p). \tag{6}
 \end{aligned}$$

It is clear from the above expansions that $E_{CD}(k, n)$ is the concatenation of p copies of $E_{CD}(k_p, \ell_p)$. Rhythms $E_{CD}(k, n)$ and $E(k, n)$ are both Euclidean up to a fixed rotation, and by Lemma 3.3 this implies that P and $E_{CD}(k_p, \ell_p)$ are rotations of each other. Consequently, P is a Euclidean rhythm.

When $\gcd(k, n) = 1$, we split the proof into two subcases depending on the value of the expression $nk_p - \ell_p k$, which by Lemma 3.1 can be equal to either $+1$ or -1 .

Consider first the case when $nk_p - \ell_p k = 1$. We will first show that $\left\lfloor \frac{in}{k} \right\rfloor = \left\lfloor \frac{i\ell_p}{k_p} \right\rfloor$ for all $i = 0, 1, \dots, k-1$. We have to show that:

$$\left\lfloor \frac{in}{k} \right\rfloor - \left\lfloor \frac{i\ell_p}{k_p} \right\rfloor = \left\lfloor \frac{i(\ell_p k + 1)}{kk_p} \right\rfloor - \left\lfloor \frac{i\ell_p}{k_p} \right\rfloor = \left\lfloor \frac{i\ell_p}{k_p} + \frac{i}{kk_p} \right\rfloor - \left\lfloor \frac{i\ell_p}{k_p} \right\rfloor = 0.$$

The above expression is true if the inequality $\frac{i\ell_p}{k_p} + \frac{i}{kk_p} < \left\lfloor \frac{i\ell_p}{k_p} \right\rfloor + 1$ holds. Let $r_i \equiv i\ell_p \pmod{k_p}$. Then,

$$\begin{aligned}
 \frac{i\ell_p}{k_p} + \frac{i}{kk_p} < \left\lfloor \frac{i\ell_p}{k_p} \right\rfloor + 1 &\Rightarrow i\ell_p + \frac{i}{k} < k_p \left\lfloor \frac{i\ell_p}{k_p} \right\rfloor + k_p \Rightarrow \frac{i}{k} < k_p \left\lfloor \frac{i\ell_p}{k_p} \right\rfloor - i\ell_p + k_p \\
 &\Rightarrow \frac{i}{k} < k_p - r_i
 \end{aligned}$$

The greatest value that $\frac{i}{k}$ can take is $\frac{k-1}{k}$, which is always less than 1; on the other hand, the smallest value that $k_p - r_i$ can take is 1. Therefore, the above inequality always holds and $\left\lfloor \frac{in}{k} \right\rfloor = \left\lfloor \frac{i\ell_p}{k_p} \right\rfloor$ for all $i = 0, 1, \dots, k-1$. This in turn, together with (6), implies that $E_{CD}(k, n)$ is formed by the concatenation of p copies of $E_{CD}(k_p, \ell_p)$ followed by the concatenation of the sequence $\left\{ p\ell_p + \left\lfloor \frac{i\ell_p}{k_p} \right\rfloor, i = 0, 1, \dots, k_t - 1 \right\}$. Since $E(k, n)$ and $E_{CD}(k, n)$ differ by a rotation, by Lemma 3.3 it follows that P is a rotation of $E_{CD}(k_p, \ell_p)$.

Now suppose that $nk_p - \ell_p k = -1$. For this case we will first show that $\left\lfloor \frac{i\ell_p}{k_p} \right\rfloor + \left\lfloor \frac{k_t\ell_p}{k_p} \right\rfloor = \left\lfloor \frac{(i+k_t)n}{k} \right\rfloor$ for $i = 0, \dots, k-1$. We start by observing that the multiplicative inverse of $\ell_p \pmod{k_p}$ is exactly k_t . This result is deduced from the equality $\ell_t k_p - \ell_p k_t = -1$, which was proved in Lemma 3.1.

If we write $n = \frac{\ell_p k - 1}{k_p}$ and perform some algebraic manipulations, we arrive at the following equality:

$$\left\lfloor \frac{(i+k_t)n}{k} \right\rfloor = \left\lfloor (i+k_t) \frac{\ell_p k - 1}{kk_p} \right\rfloor = \left\lfloor \frac{i\ell_p}{k_p} - \frac{i}{kk_p} + \frac{k_t\ell_p}{k_p} - \frac{k_t}{kk_p} \right\rfloor = \left\lfloor \frac{i\ell_p}{k_p} + \frac{k_t\ell_p}{k_p} - \frac{i+k_t}{kk_p} \right\rfloor.$$

Let r_i be the remainder of the integer division of $i\ell_p$ by k_p . Since $k_t\ell_p = 1 \pmod{k_p}$, we can write:

$$\left\lfloor \frac{i\ell_p}{k_p} + \frac{k_t\ell_p}{k_p} - \frac{i+k_t}{kk_p} \right\rfloor = \left\lfloor \frac{i\ell_p}{k_p} \right\rfloor + \left\lfloor \frac{k_t\ell_p}{k_p} \right\rfloor + \left\lfloor \frac{r_i + 1}{k_p} - \frac{i+k_t}{kk_p} \right\rfloor.$$

Finally, the expression we seek to prove is reduced to the following equation:

$$\left\lfloor \frac{(i+k_t)n}{k} \right\rfloor - \left\lfloor \frac{i\ell_p}{k_p} \right\rfloor - \left\lfloor \frac{k_t\ell_p}{k_p} \right\rfloor = \left\lfloor \frac{r_i + 1}{k_p} - \frac{i+k_t}{kk_p} \right\rfloor.$$

Therefore, we must prove that the inequality $0 \leq \frac{r_i + 1}{k_p} - \frac{i+k_t}{kk_p} < 1$ is true. By multiplying the inequality by kk_p , we obtain:

$$0 \leq \frac{r_i + 1}{k_p} - \frac{i+k_t}{kk_p} < 1 \Rightarrow 0 \leq k(r_i + 1) - (i+k_t) < kk_p$$

The greatest value the expression $k(r_i + 1) - (i+k_t)$ can attain is $k(k_p - 1 + 1) - (0 + 1) = kk_p - 1 < kk_p$. To show that $k(r_i + 1) - (i+k_t)$ is always non-negative, we distinguish two cases. If k_p divides i , then $r_i = 0$ and the smallest value of our expression is $k(0 + 1) - (pk_p + k_t) = 0$. If k_p does not divide i , then $r_i \geq 1$ and the smallest value of our expression is $k(1 + 1) - (k - 1 + k_t) = k - k_t + 1 > 0$. Therefore, the above inequality is always true, and hence $\left\lfloor \frac{i\ell_p}{k_p} \right\rfloor + \left\lfloor \frac{k_t\ell_p}{k_p} \right\rfloor = \left\lfloor \frac{(i+k_t)n}{k} \right\rfloor$ for $i = 0, \dots, k-1$. From Observation 3.2 we know that $\left\{ \left\lfloor \frac{(i+k_t)n}{k} \right\rfloor \pmod{n}, i = 0, \dots, k-1 \right\}$ is $E_{CD}(k, n)$ starting from the onset at position k_t , and $\left\{ \left\lfloor \frac{i\ell_p}{k_p} \right\rfloor + \left\lfloor \frac{k_t\ell_p}{k_p} \right\rfloor \pmod{n}, i = 0, \dots, k-1 \right\}$ is a rotation of $E_{CD}(k, n)$ by $\left\lfloor \frac{k_t\ell_p}{k_p} \right\rfloor$, which, moreover, is in the hypothesis of Lemma 3.3. Hence, P is the Euclidean rhythm $E_{CD}(k_p, \ell_p)$ up to a rotation. This completes the proof of the theorem. ■

It remains to prove that rhythm $\left\{ p\ell_p + \left\lfloor \frac{i\ell_p}{k_p} \right\rfloor, i = 0, 1, \dots, k_t - 1 \right\}$, is, in fact, $E(k_t, \ell_t)$ up to a rotation. The next theorem settles this question.

THEOREM 3.5 *The tail pattern of rhythm $E(k, n)$ is Euclidean up to a rotation.*

Proof: The tail pattern T has nonzero length when $\gcd(k, n) = 1$. If $n = 1 \pmod{k}$, from

Bjorklund’s algorithm we know that the tail is the Euclidean rhythm $\{0\}$. Assume now that $n \neq 1 \pmod k$. This implies that $k_t \neq 0$.

The proof of this case is very similar to the proof of the previous theorem. We again split the proof into two subcases based on the value of $\ell_p k_t - \ell_t k_p$, which by Lemma 3.1 can be either 1 or -1 .

Assume first that $\ell_p k_t - \ell_t k_p = 1$. We will prove that $\left\lfloor \frac{i\ell_p}{k_p} \right\rfloor = \left\lfloor \frac{i\ell_t}{k_t} \right\rfloor$, for $i = 0, \dots, k_p - 1$.

$$\left\lfloor \frac{i\ell_p}{k_p} \right\rfloor - \left\lfloor \frac{i\ell_t}{k_t} \right\rfloor = 0 \Rightarrow \left\lfloor \frac{i(\ell_t k_p + 1)}{k_t k_p} \right\rfloor - \left\lfloor \frac{i\ell_t}{k_t} \right\rfloor = 0 \Rightarrow \left\lfloor \frac{i\ell_t}{k_t} + \frac{i}{k_t k_p} \right\rfloor - \left\lfloor \frac{i\ell_t}{k_t} \right\rfloor = 0.$$

The above expression is true if the following inequality holds:

$$\frac{i\ell_t}{k_t} + \frac{i}{k_t k_p} < \left\lfloor \frac{i\ell_t}{k_t} \right\rfloor + 1.$$

Substituting $r_i = i\ell_t \pmod{k_t}$ in the above inequality, with an argument similar to the one in the proof of Theorem 3.4, we can show that this inequality is always true and hence T is Euclidean. We omit the details for conciseness.

For the case $\ell_p k_t - \ell_t k_p = -1$, we will show that $\left\lfloor \frac{i\ell_t}{k_t} \right\rfloor + \left\lfloor \frac{\alpha\ell_t}{k_t} \right\rfloor = \left\lfloor \frac{(i+\alpha)\ell_p}{k_p} \right\rfloor$, for $i = 0, \dots, k_p - 1$ and for some value α . Let $r_i \equiv i\ell_t \pmod{k_t}$, where $0 \leq r_i \leq k_t - 1$. As for α , it will be chosen as the multiplicative inverse of ℓ_t , that is, α satisfies the equality $\alpha\ell_t \equiv 1 \pmod{k_t}$ with $0 \leq \alpha \leq k_t - 1$. Actually, $\alpha \equiv k_p \pmod{k_t}$. This fact falls out from equality $\ell_p k_t - \ell_t k_p = -1$ (Lemma 3.1). when we take $\pmod{k_t}$ of both sides of the equation.

$$\begin{aligned} \left\lfloor \frac{(i+\alpha)\ell_p}{k_p} \right\rfloor &= \left\lfloor (i+\alpha) \frac{\ell_t k_p - 1}{k_t k_p} \right\rfloor = \left\lfloor \frac{i\ell_t}{k_t} - \frac{i}{k_t k_p} + \frac{\alpha\ell_t}{k_t} - \frac{\alpha}{k_t k_p} \right\rfloor \\ &= \left\lfloor \frac{i\ell_t}{k_t} + \frac{\alpha\ell_t}{k_t} - \frac{i+\alpha}{k_t k_p} \right\rfloor = \left\lfloor \frac{i\ell_t}{k_t} \right\rfloor + \left\lfloor \frac{\alpha\ell_t}{k_t} \right\rfloor + \left\lfloor \frac{r_i + 1}{k_t} - \frac{i+\alpha}{k_t k_p} \right\rfloor. \end{aligned}$$

If the following inequality holds,

$$0 \leq \frac{r_i + 1}{k_t} - \frac{i+\alpha}{k_t k_p} < 1 \implies 0 \leq k_p(r_i + 1) - (i+\alpha) < k_t k_p,$$

then the equality $\left\lfloor \frac{i\ell_t}{k_t} \right\rfloor + \left\lfloor \frac{\alpha\ell_t}{k_t} \right\rfloor = \left\lfloor \frac{(i+\alpha)\ell_p}{k_p} \right\rfloor$ will also hold.

The upper bound of $k_p(r_i + 1) - (i+\alpha)$ is $k_p(k_t - 1 + 1) - (0 + 1) = k_p k_t - 1 < k_p k_t$. To show that $k_p(r_i + 1) - (i+\alpha)$ is always nonnegative, we analyze two subcases. If k_t does not divide i , then since ℓ_t and k_t are relatively prime, r_i must at least 1. Thus, the lower bound for our expression in this case is $k_p(1 + 1) - (k_p - 1 + k_t - 1) = k_p - k_t + 2 > 0$. Now suppose k_t divides i ; then, $r_i = 0$ and the greatest value of i that is divisible by k_t is $k_t \left\lfloor \frac{k_p}{k_t} \right\rfloor$.

Thus, the lower bound in this case is $k_p(0+1) - \left(k_t \left\lfloor \frac{k_p}{k_t} \right\rfloor + \alpha\right) = k_p - (k_p - \alpha + \alpha) = 0$. This completes the proof of the theorem. ■

If P admits a decomposition $P = Q \oplus .? \oplus Q$, for certain $q > 1$, then $E(k, n)$ can be written as the concatenation of a pattern Q of a smaller number of pulses. We will now show that, in fact, P does not admit such a decomposition, and therefore is *minimal*. First we show that the rhythm obtained by removing the tail of a Euclidean rhythm remains Euclidean. Note that this fact does not follow immediately from the preceding two theorems, as the main pattern in a Euclidean rhythm depends on its number of pulses and onsets; removing the tail changes these numbers, and it is thus not clear what the main pattern in a Euclidean rhythm with fewer pulses looks like.

THEOREM 3.6 *Let k and n be two integers with $\gcd(k, n) = 1$. If $E(k, n) = P \oplus .? \oplus P \oplus T$ is the decomposition given by Bjorklund's algorithm, then rhythm $P \oplus .? \oplus P$ is a rotation of $E(k_p p, \ell_p p)$.*

Proof: It is sufficient to prove the result for the Clough-Douthett representation $E_{CD}(k_p, \ell_p)$ of P . By concatenating p copies of $E_{CD}(k_p, \ell_p)$ we obtain:

$$\begin{aligned}
& E_{CD}(k_p, \ell_p) \oplus .? \oplus E_{CD}(k_p, \ell_p) \\
&= \left\{ 0, \left\lfloor \frac{\ell_p}{k_p} \right\rfloor, \dots, \left\lfloor \frac{(k_p-1)\ell_p}{k_p} \right\rfloor, \ell_p, \ell_p + \left\lfloor \frac{\ell_p}{k_p} \right\rfloor, \dots, \ell_p + \left\lfloor \frac{(k_p-1)\ell_p}{k_p} \right\rfloor, \dots, \right. \\
&\quad \left. \ell_p(p-1), \ell_p(p-1) + \left\lfloor \frac{\ell_p}{k_p} \right\rfloor, \dots, \ell_p(p-1) + \left\lfloor \frac{(k_p-1)\ell_p}{k_p} \right\rfloor \right\} \\
&= \left\{ 0, \left\lfloor \frac{p\ell_p}{pk_p} \right\rfloor, \dots, \left\lfloor \frac{(k_p-1)p\ell_p}{pk_p} \right\rfloor, \ell_p, \ell_p + \left\lfloor \frac{p\ell_p}{pk_p} \right\rfloor, \dots, \ell_p + \left\lfloor \frac{(k_p-1)p\ell_p}{pk_p} \right\rfloor, \dots, \right. \\
&\quad \left. \ell_p(p-1), \ell_p(p-1) + \left\lfloor \frac{p\ell_p}{pk_p} \right\rfloor, \dots, \ell_p(p-1) + \left\lfloor \frac{(k_p-1)p\ell_p}{pk_p} \right\rfloor \right\} \\
&= \left\{ 0, \left\lfloor \frac{p\ell_p}{pk_p} \right\rfloor, \dots, \left\lfloor \frac{(k_p-1)p\ell_p}{pk_p} \right\rfloor, \left\lfloor \frac{\ell_p pk_p}{pk_p} \right\rfloor, \left\lfloor \frac{\ell_p pk_p + p\ell_p}{pk_p} \right\rfloor, \dots, \left\lfloor \frac{\ell_p pk_p + (k_p-1)p\ell_p}{pk_p} \right\rfloor, \dots, \right. \\
&\quad \left. \left\lfloor \frac{pk_p \ell_p (p-1)}{pk_p} \right\rfloor, \left\lfloor \frac{pk_p \ell_p (p-1)}{pk_p} + \frac{p\ell_p}{pk_p} \right\rfloor, \dots, \left\lfloor \frac{pk_p \ell_p (p-1)}{pk_p} + \frac{(k_p-1)p\ell_p}{pk_p} \right\rfloor \right\} \\
&= \left\{ 0, \left\lfloor \frac{p\ell_p}{pk_p} \right\rfloor, \dots, \left\lfloor \frac{(k_p-1)p\ell_p}{pk_p} \right\rfloor, \left\lfloor \frac{\ell_p pk_p}{pk_p} \right\rfloor, \dots, \left\lfloor \frac{(pk_p-1)p\ell_p}{pk_p} \right\rfloor \right\} = E_{CD}(pk_p, p\ell_p).
\end{aligned}$$

Therefore, the concatenation of p copies of the main pattern P is a rotation of $E(k_p p, \ell_p p)$. ■

THEOREM 3.7 *The main pattern P of $E(k, n)$ is minimal.*

Proof: Assume first that $\gcd(k, n) = d > 1$. If Q is a pattern such that $P = Q \oplus .? \oplus Q$,

for some $q \geq 1$, then the number qp must divide both n and k . Since in this case $p = d$, it follows that $q = 1$, and therefore, $P = Q$.

Assume now that $\gcd(k, n) = 1$. By Theorem 3.6, removing the tail pattern of $E(k, n)$ will give us the rhythm $E(k_p p, \ell_p p)$ up to a rotation. By the previous case, the main pattern P of $E(k_p p, \ell_p p)$ cannot be written as the concatenation of copies of a shorter pattern Q . Thus, the main pattern of $E(k, n)$ is minimal. ■

4. Concluding Remarks

In this paper we have studied the structure of Euclidean rhythms. We started by showing the connection between Euclid's and Bjorklund's algorithms. Some algorithms generating Euclidean rhythms are based on the idea of distributing the pulses from the beginning. This is the idea behind both the Clough-Douthett formula: $\{\lfloor \frac{ni}{k} \rfloor, i = 0, 1, \dots, k-1\}$, and the snap algorithm described in [10]. On the other hand, Bjorklund's algorithm is a more constructive algorithm, and is based on grouping the onsets as the rhythm is built. We have shown a clear connection between Euclid's algorithm and the generation of Euclidean rhythms through Bjorklund's algorithm. Next, we showed that the output of Bjorklund's algorithm is the concatenation of several copies of a main pattern plus possibly a tail pattern, both of which were shown to be Euclidean.

During the course of the proofs, a connection between Euclidean rhythms and Bezout's theorem was revealed; when k and n are relatively prime, k_p , the number of onsets of P , and ℓ_p , the number of pulses of P , are exactly the absolute values of the Bezout coefficients of k and n .

We proved that a Euclidean rhythm with k onsets and n pulses can be decomposed as $E(k, n) = P \oplus \dots \oplus P \oplus T$, where T is empty when $\gcd(k, n) > 1$. Furthermore, we proved that P and T are Euclidean themselves, which shows the recursive nature of Euclidean rhythms. This decomposition is minimal, that is, $E(k, n)$ does not admit a decomposition where the main pattern has fewer pulses.

Acknowledgements

Francisco Gómez would like to thank Lola Álvarez and Jesus García for fruitful discussions. Perouz Taslakian would like to thank Victor Campos for the fun and exciting conversations on the topic of this paper.

References

- [1] E. Bjorklund. The theory of rep-rate pattern generation in the SNS timing system. SNS ASD Technical Note SNS-NOTE-CNTRL-99, Los Alamos National Laboratory, Los Alamos, U.S.A., 2003.
- [2] J. E. Bresenham. Algorithm for computer control of digital plotter. *IBM Systems Journal*, 4:25–30, 1965.
- [3] A. M. Bruckstein. Self-similarity properties of digital straight lines. In R. A. Melter, A. Rosenfeld, and P. Bhattacharya, editors, *Vision Geometry*, pages 1–20. American Mathematical Society, Providence, Rhode Island, 1991.
- [4] N. Carey and D. Clampitt. Self-similar pitch structures, their duals, and rhythmic analogues. *Perspectives of New Music*, 34(2):62–87, 1996.
- [5] J. Clough and J. Douthett. Maximally even sets. *Journal of Music Theory*, 35:93–173, 1991.
- [6] J. Clough and G. Myerson. Variety and multiplicity in diatonic systems. *Journal of Music Theory*, 29:249–270, 1985.
- [7] T. H. Cormen, C. E. Leiserson, R. L. Rivest, and C. Stein. *Introduction to Algorithms*. The MIT Press, Boston, MA, second edition edition, 2001.
- [8] N. G. de Bruijn. Sequences of zeros and ones generated by special production rules. *Indagationes Mathematicae*, 43:27–37, 1981.
- [9] N. G. de Bruijn. Updown generation of Beatty sequences. *Indagationes Mathematicae*, 51:385–407, 1989.
- [10] E. D. Demaine, F. Gomez-Martin, H. Meijer, D. Rappaport, P. Taslakian, G. T. Toussaint, T. Winograd, and D. R. Wood. The distance geometry of music. *Computational Geometry: Theory and Application*, 2008. To appear.
- [11] J. Ellis, F. Ruskey, J. Sawada, and J. Simpson. Euclidean strings. *Theoretical Computer Science*, 301:321–340, 2003.
- [12] R. L. Graham, S. Lin, and C.-S. Lin. Spectra of numbers. *Mathematics Magazine*, 51:174–176, 1978.
- [13] M. A. Harris and E. M. Reingold. Line drawing, leap years, and Euclid. *ACM Computing Surveys*, 36(1):68–80, March 2004.
- [14] R. Klette and A. Rosenfeld. Digital straightness - a review. *Discrete Applied Mathematics*, 139:197–230, 2004.
- [15] D. Lewin. Cohn functions. *Journal of Music Theory*, 40(2):181–216, Autumn 1996.
- [16] M. Lothaire. *Algebraic Combinatorics on Words*. Cambridge University Press, Cambridge, England, 2002.
- [17] W. F. Lunnon and P. A. B. Pleasants. Characterization of two-distance sequences. *Journal of the Australian Mathematical Society (Series A)*, 53:198–218, 1992.
- [18] C. Series. The geometry of Markoff numbers. *The Mathematical Intelligencer*, 7(3):20–29, 1985.